

eco
OPTIDRIVE™

Energy efficient pumping
with **OPTIFLOW™**

0.75kW – 250kW / 1HP – 350HP
200 – 600V Single & 3 Phase Input

IP20

IP55

IP66



Reduced Harmonic Distortion (THDI)

- Meets EN 61000-3-12 without external equipment

Higher Input Power Factor

Improved Efficiency

IE2, IE3 and IE4 Motor Control

Improved Performance

Dedicated Pump Control Features

Added Flexibility



Dedicated Fan & Pump Drive

0.75 – 250kW / 1.0 – 350 HP

Focus on Ease of Use

Dedicated Pump Features:

- BACnet (RJ45 connector)
- Cascade Control Pump Staging
- Pump Dry Run Protection
- Auto Pump Cleaning Function
- Auto Pump – Stir Function
- PID Loop w/ Sleep & Wake Levels
- Motor Pre-heat.



Seven Frame Sizes

- FS2 – FS8

0.75 – 250kW (1 - 350HP)

200 – 600 Volt

- 200 – 240 Volt, 1 Phase Input, 0.75 – 2.2kW
- 200 – 240 Volt, 3 Phase Input, 0.75 – 75kW
- 380 – 480 Volt, 3 Phase Input, 0.75 – 250kW
- 480 – 525 Volt, 3 Phase Input, 150 – 200kW
- 500 – 600 Volt, 3 Phase Input, 0.75 – 110kW

IP20, IP55, IP66

- IP20 FS 2, 3, 4, 5, 8
- IP66 FS 2, 3
- IP55 FS4, 5, 6, 7



IP20

Frame Sizes 2 – 5 (+8)

- ✓ Panel mounting design
- ✓ Fan Cooled



IP66

Frame Sizes 2 – 3

- ✓ Wall mounting design
- ✓ With / Without Isolator
- ✓ Convection Cooled



IP55

Frame Sizes 4 – 7

- ✓ Wall mounting
- ✓ Fan Cooled



Optidrive Eco Energy Efficiency



Save Energy, Cut CO₂



eco
OPTIDRIVE™

Optidrive Eco – Green Credentials

A Responsibility to the Customer, and to the environment...

- Designed for Maximum Motor Control Efficiency
- RoHS Manufactured
- Intelligent Standby
- Energy Optimisation
- EN61000-3-12 Compliant



Optidrive Eco – Green Credentials A Responsibility to the Customer, and to the environment...

Energy Estimation Tool

- Available as Simple Website Form
- Available as Download Application
- Predicts Energy Usage
- Predicts Energy Savings
- Predicts CO2 Usage
- Predicts CO2 Savings



Optidrive Eco Key Features



OLED Display

OLED Multi Language Plain Text Display

- Factory Fit and Stand Alone Options
- Multi-Line Text Display
- Instant visibility for Voltage, Current, Power, Operating Condition
- High visibility from virtually any angle
- User Defined / Scaled Parameters Displayed
- Common languages supported.



Keypad Operation



Used to display real-time information, to access and exit parameter edit mode and to store parameter changes.



Used to increase speed in real-time mode or to increase parameter values in parameter edit mode.



Used to decrease speed in real-time mode or to decrease parameter values in parameter edit mode



Used to reset a tripped drive.
When in Keypad mode is used to Stop a running drive.



When in keypad mode, used to Start a stopped drive or to reverse the direction of rotation if bi-directional keypad mode is enabled



Hand mode, places drive directly under keypad control



Auto mode, places drive under auto control configured by P1-13.
Normally set to BMS control.

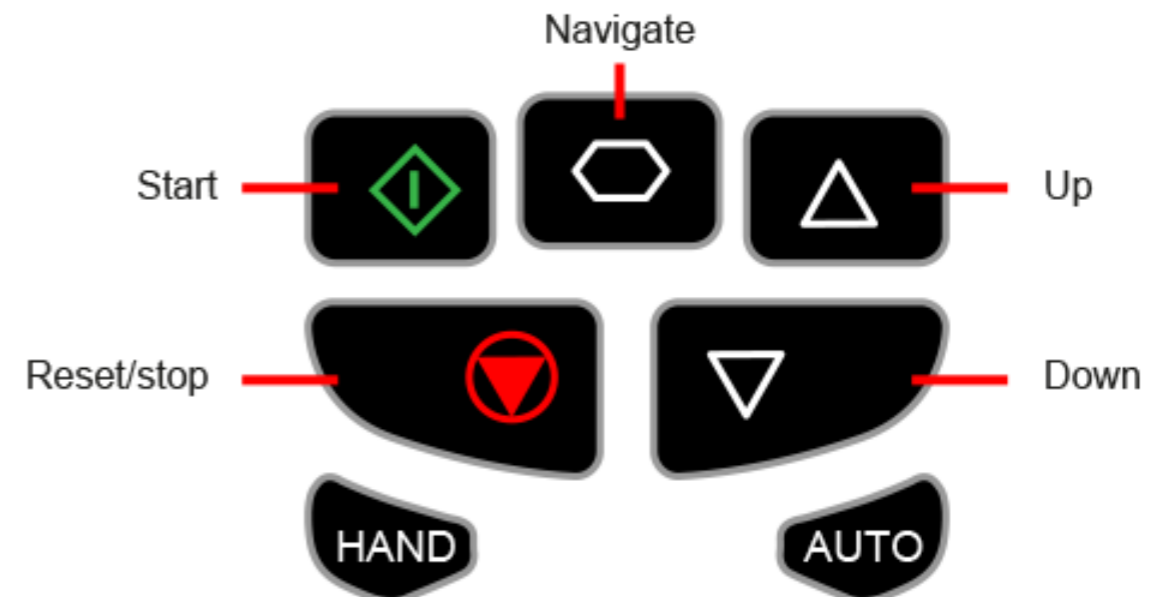

Communications Interface

On board interfaces for

- BACnet MS/TP
- Modbus RTU

Optional Plug in interfaces for:

BACnet IP



EtherCat



DeviceNet



Profibus DPV1



Modbus TCP



EtherCat



ProfiNet



Diagnostics

Service Indicators and Procedures

- Settable Service Interval parameter for routine drive or system maintenance alerts.
- Read Only 'Time to Service' parameter in diagnostics menu
- Displayed flashing service indicator on OLED display when service is due.
- Drive outputs configurable for service due indication
- Simple Service 'reset' procedure
- Invertek recommended drive service procedure and checks published for increased product life.



OPTIFLOW™

Control for Pumps



PID Sleep / Standby Function

- The drive has an internal PID that can be used to modulate the motor speed to control pressure, temperature, flow etc.
- To maximise on energy saving and prevent situations like pumping a dead head, a Sleep / Standby mode is available
- The drive enters standby/sleep mode when enabled if the motor frequency/speed is at or below the 'standby speed threshold' for the time set in 'Standby Timer'
- In Standby/Sleep Mode, the display shows 'Standby'
- In PID Mode, the drive 'wake-up' is configured based on the PID Error – the difference between the setpoint and the actual feedback



PID Boost

When operating in PID control, a pre boost function allows the drive to operate at a fixed speed for a preset time prior to entering sleep mode. This prevents the drive continually cycling in and out of sleep mode, increases the sleep time and hence energy savings

- P6-11 Sets the time that the drive will operate at fixed speed for on starting
 - 0.0 – 250.0 Seconds Range
- Drive operates at Preset Speed 7 (P2-07) during this time
- The drive can also be programmed to restart at a fixed speed for a fixed time on wake up, to allow the PID control to adjust
- P6-12 Sets the time that the drive will operate at fixed speed for before stopping
 - 0.0 – 250.0 Seconds Range
- Drive operates at Preset Speed 7 (P2-08) during this time

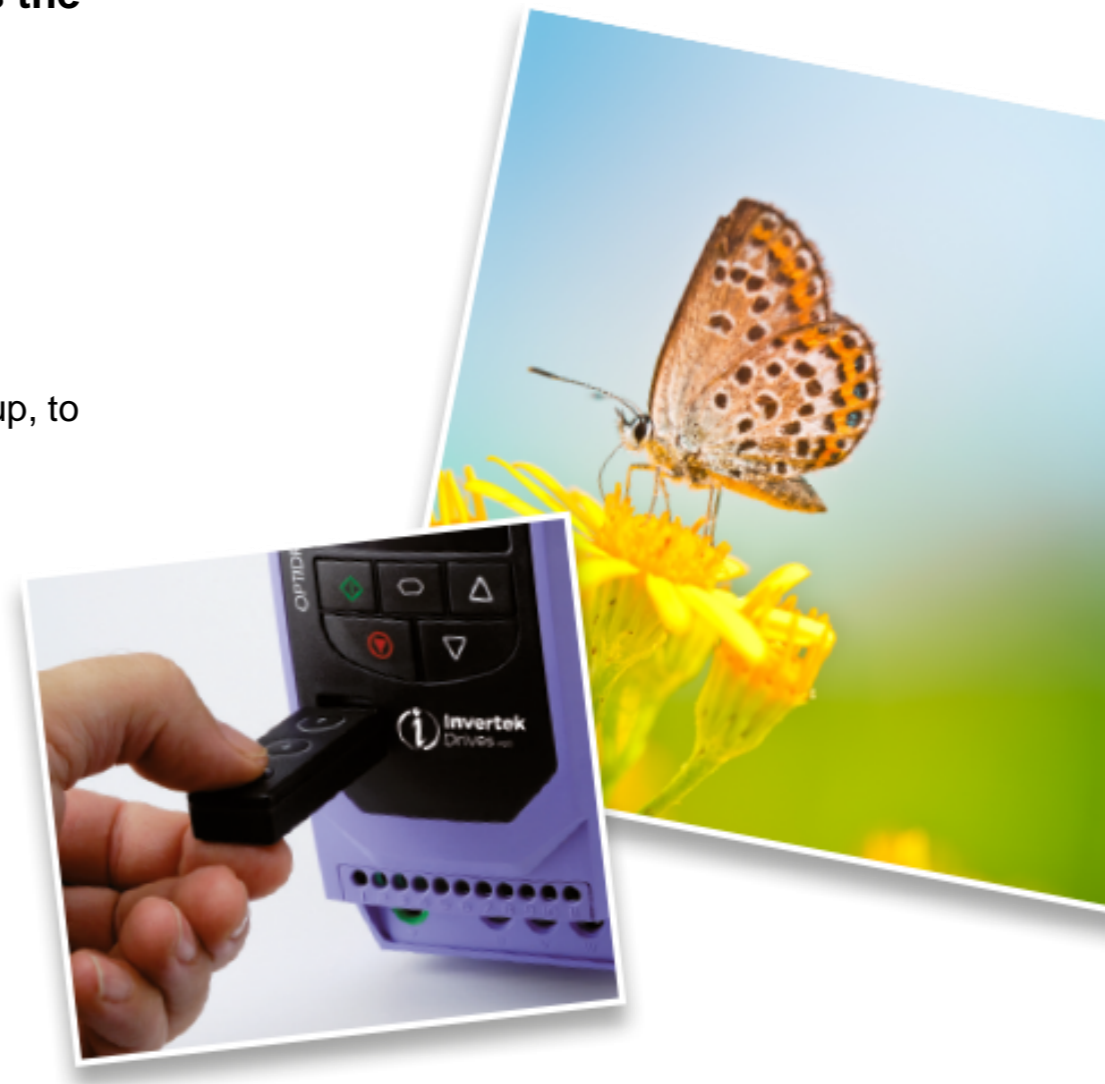

Pump Stir Function

- The Pump Stir function prevents the pump remaining inoperative for long periods of time (whilst in Sleep Mode).
- After a User adjustable time limit is exceeded in Sleep Mode, the drive operates the pump at a preset speed for a preset time. This is used to prevent pump blockage caused by sediment build up
- When the drive enters into standby mode an internal timer is started.
- When the timer exceeds the parameter defined time limit, a preset motion profile is activated.
- When the stir cycle is complete, the drive returns immediately to standby mode.
- The activation timer is reset.



Pump Stir Function

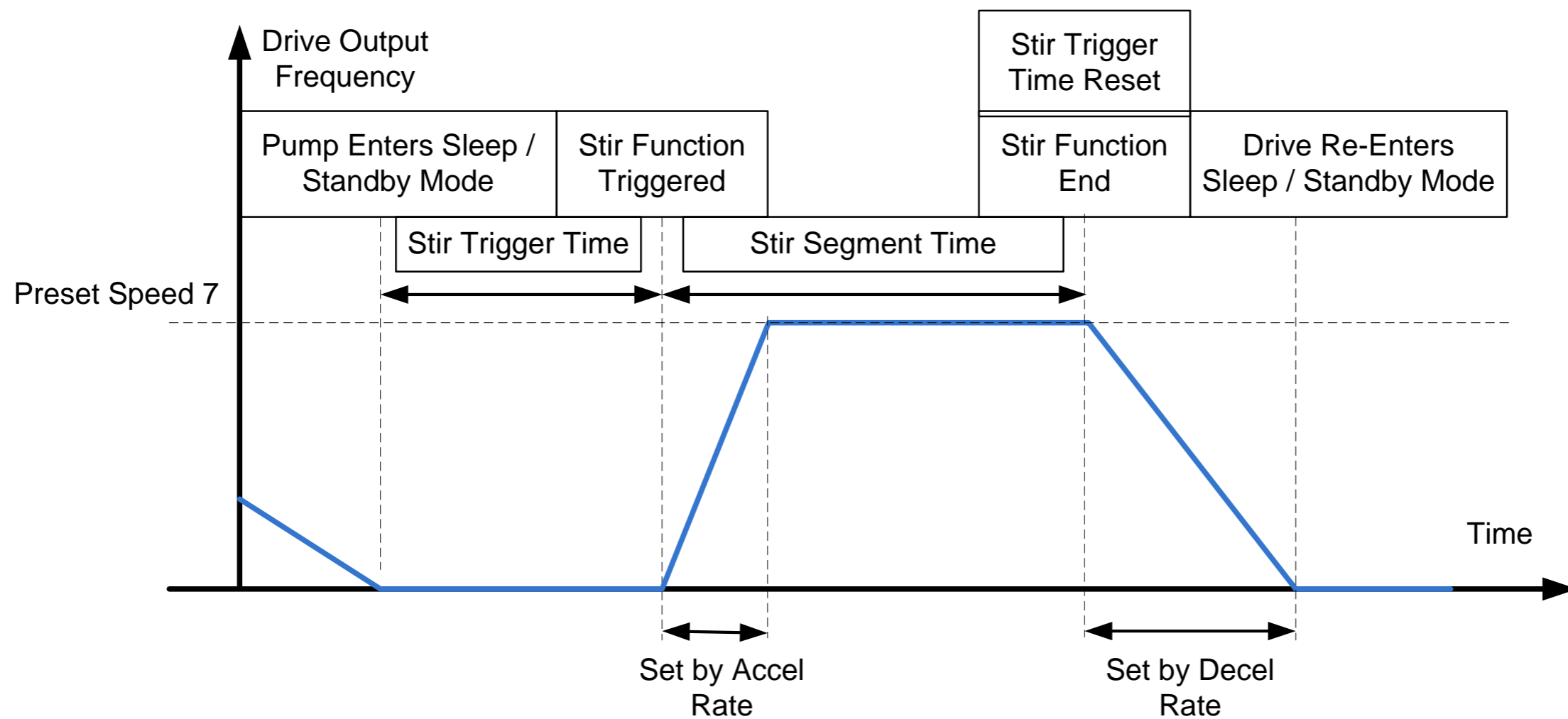

Pump Cleaning Function

- Bi-Directional Pump Cleaning Function
- Can be activated by the Pump Blockage Detection (See Later)
- Can be automatically executed following a start command
- Can be triggered by a digital input
- Can be initiated by the internal PLC function for example based on a simple timer
- Separate ramp times allow a fast ramp for pump cleaning, slower ramps for normal operation

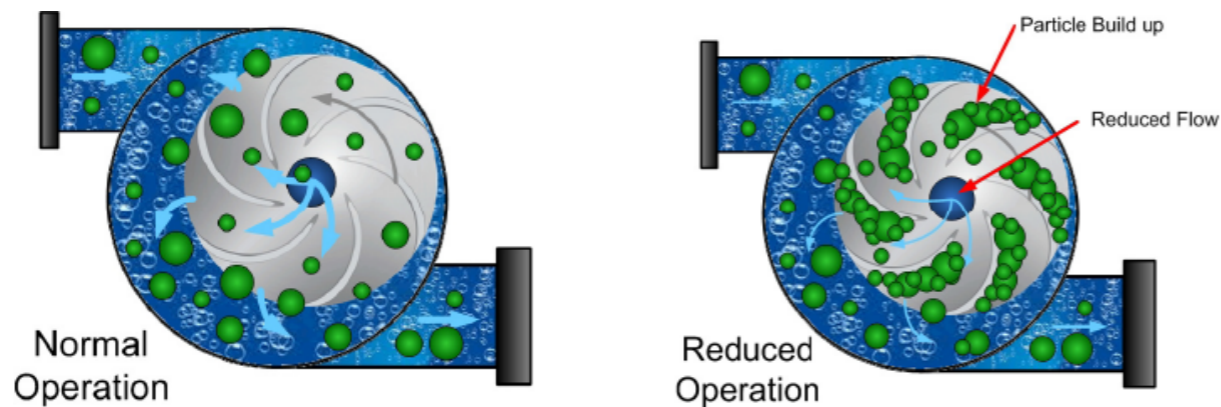

Typical Sump Pump Application

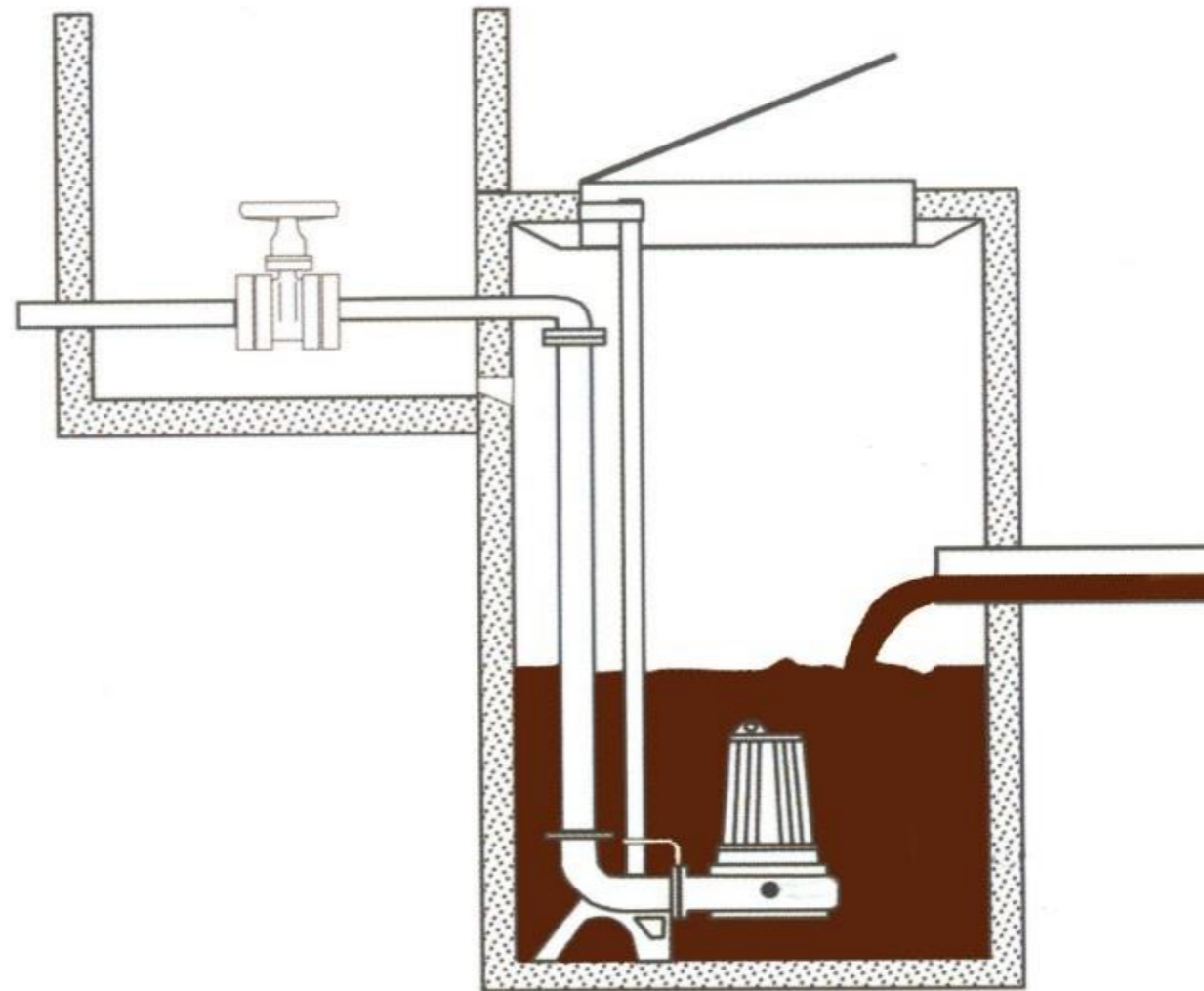

Operating Profile

Pump Cleaning On Start Example

- During the cleaning cycle, P8-05 controls Accel and Decel rates
- After the cleaning cycle, P1-03 and P1-04 control as normal
- P8-04 controls the time for cleaning operation. Note that some of this time will be required for the ramps, P8-04 sets the total time
- If P2-05 = 0, the pump runs forwards only, for the time set in P8-04. This can be useful where pumps cannot be reversed

Parameter Number	Description
P2-05	Clean Speed 1
P2-06	Clean Speed 2
P8-04	Pump Cleaning Function Time Interval
P8-05	Pump Cleaning Function Ramp Time
P1-04	Deceleration Ramp Time

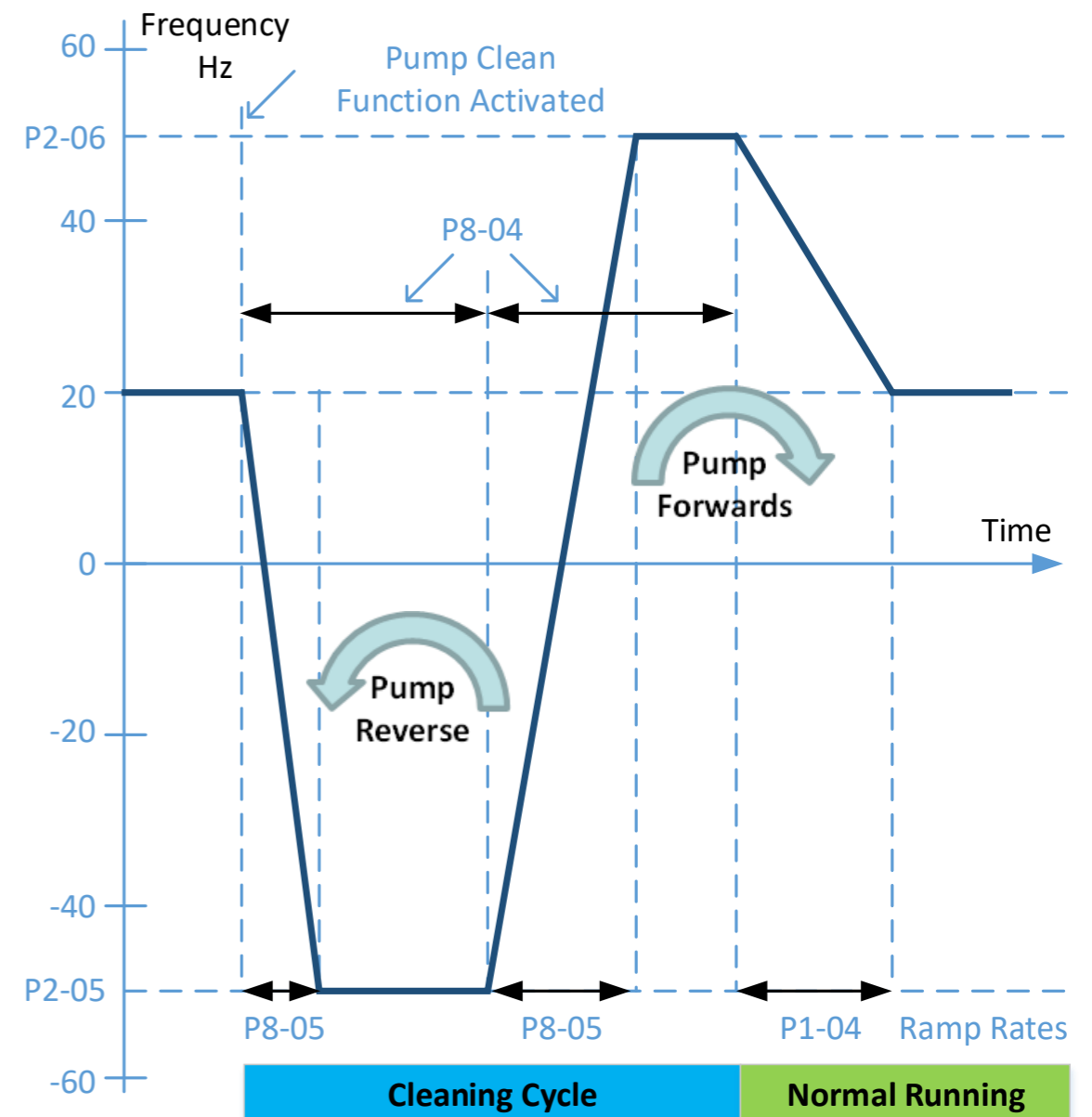

Test Site Example

- Longford WWTW, County Longford, Ireland
- 2 x Optidrive Eco 37kW units
- Drives operating submersible pumps in continuous operation
- The existing fixed speed control had frequent problems with pump blockages requiring pump removal and cleaning on a weekly basis
- The drives were installed and operated with the pumps to check operation
 - The pumps run at fixed speed (35Hz)
 - Output current was logged during the testing



Output Current Log Before Cleaning

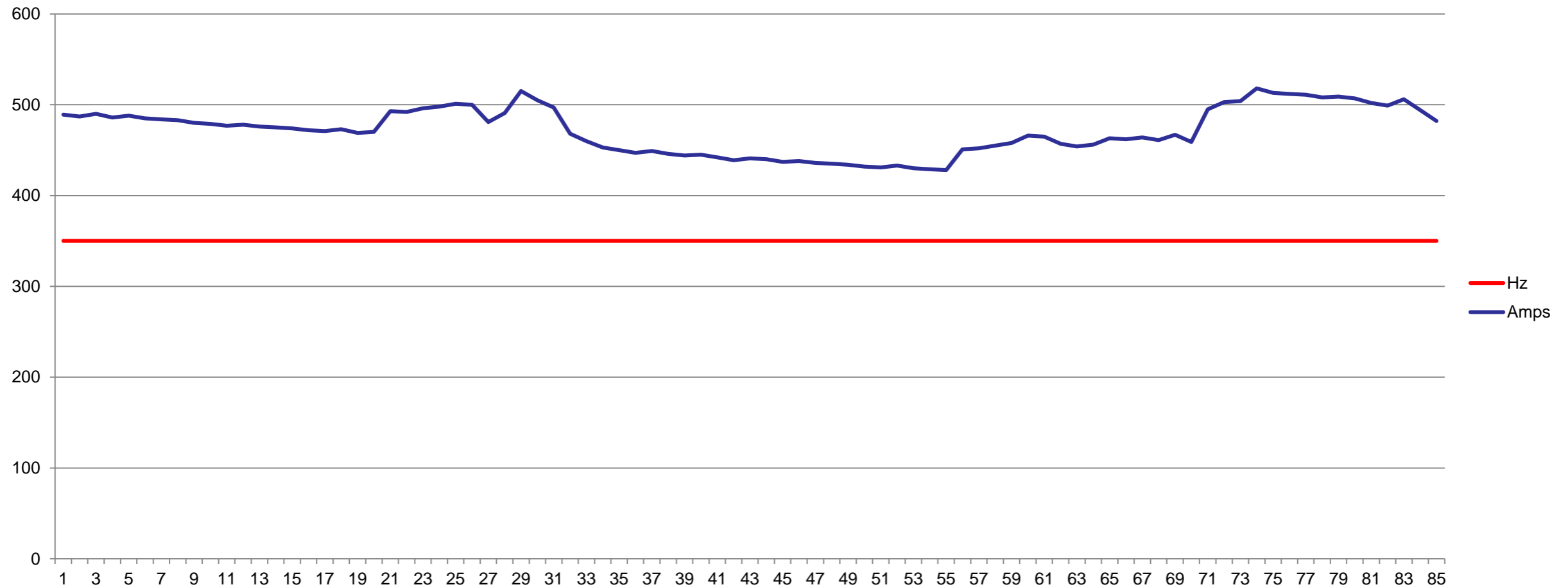

The graph above shows the current drawn by the pump on the initial test run, with operation at constant speed (35Hz output frequency). The time period of the test data is approximately 4 minutes, and shows the pump current drawn to be a minimum of 42.8 Amps, maximum 51.3 Amps, average 47 Amps.

Test Site Example

Cleaning Function Set Up

- Cleaning function was initially set for Pump Cleaning on Start
 - P8-03 = 1
- A non-return valve was present in the pump inlet
 - Operating speed in reverse had to be limited to prevent high current
 - P2-05 = 37.5Hz
 - Operating time was kept short to prevent damage to the pump and pipework
 - P8-04 = 10 Seconds
 - In the forward direction, the pump could be safely operated at full speed
 - P2-06 = 50.0Hz
 - Acceleration times were tested, and the shortest possible ramp time without over current trip was used
 - P8-05 = 4.0 Seconds

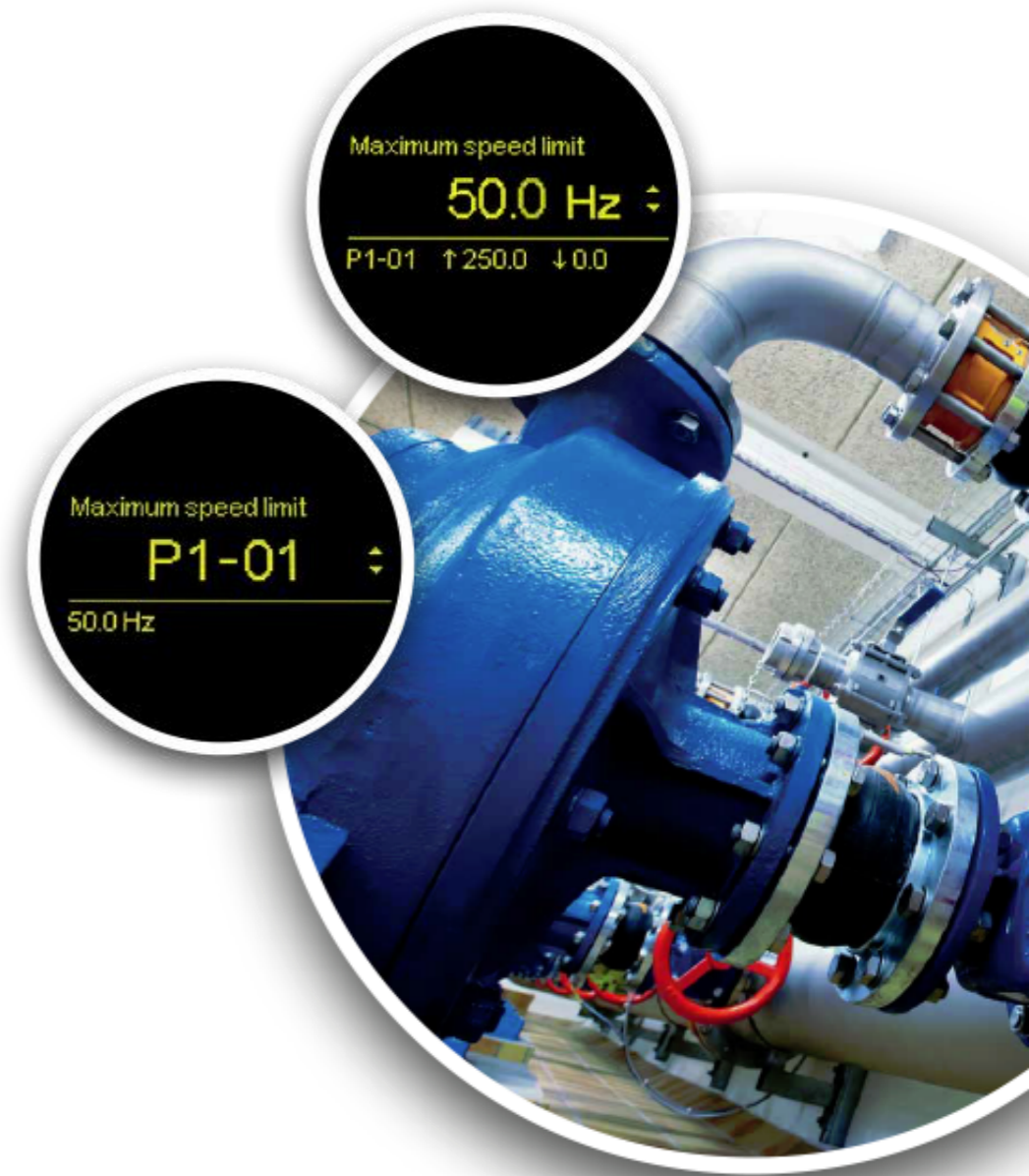

Hz Vs Amps During Clean Cycle

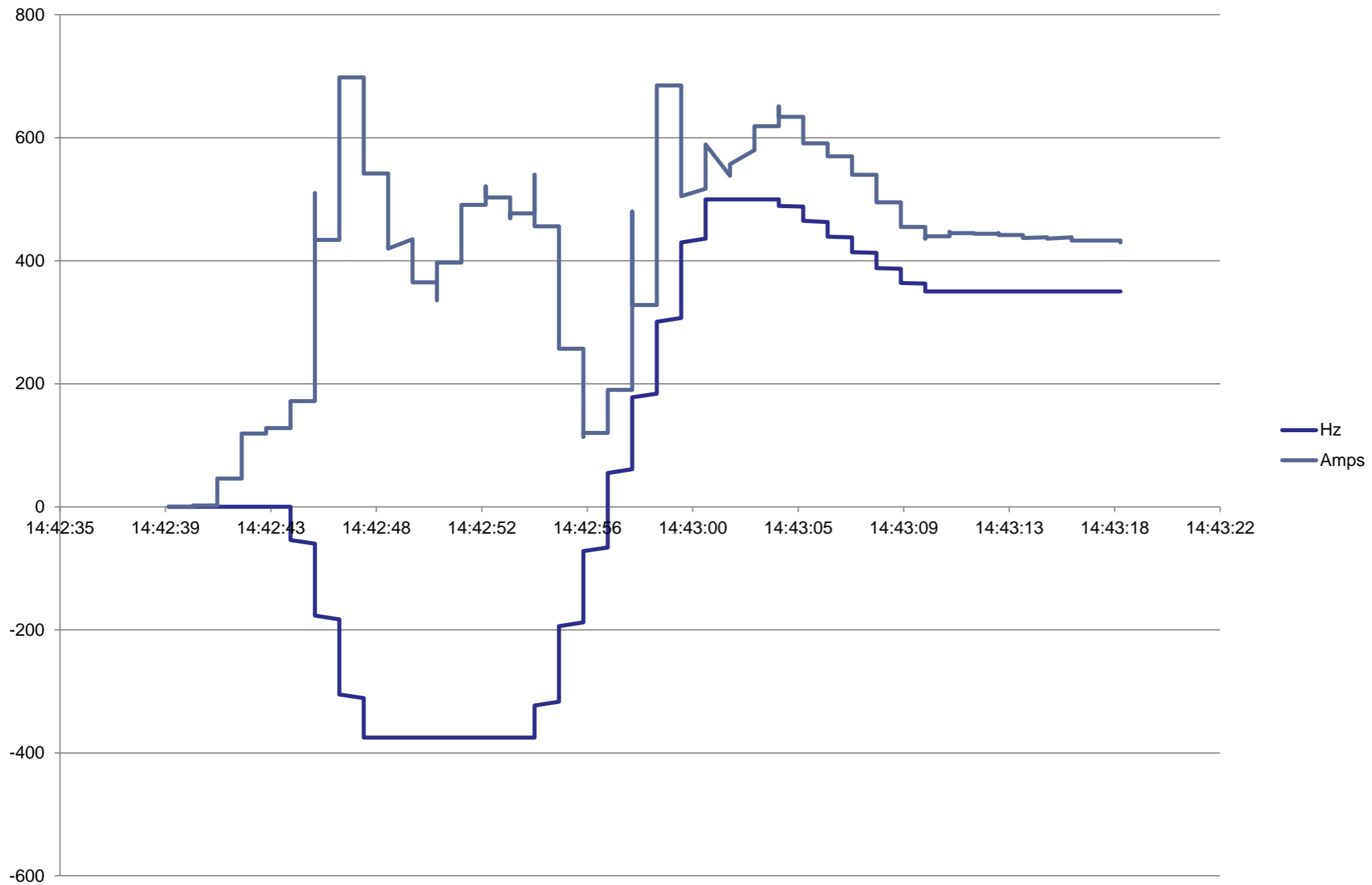

Operating Log after Cleaning

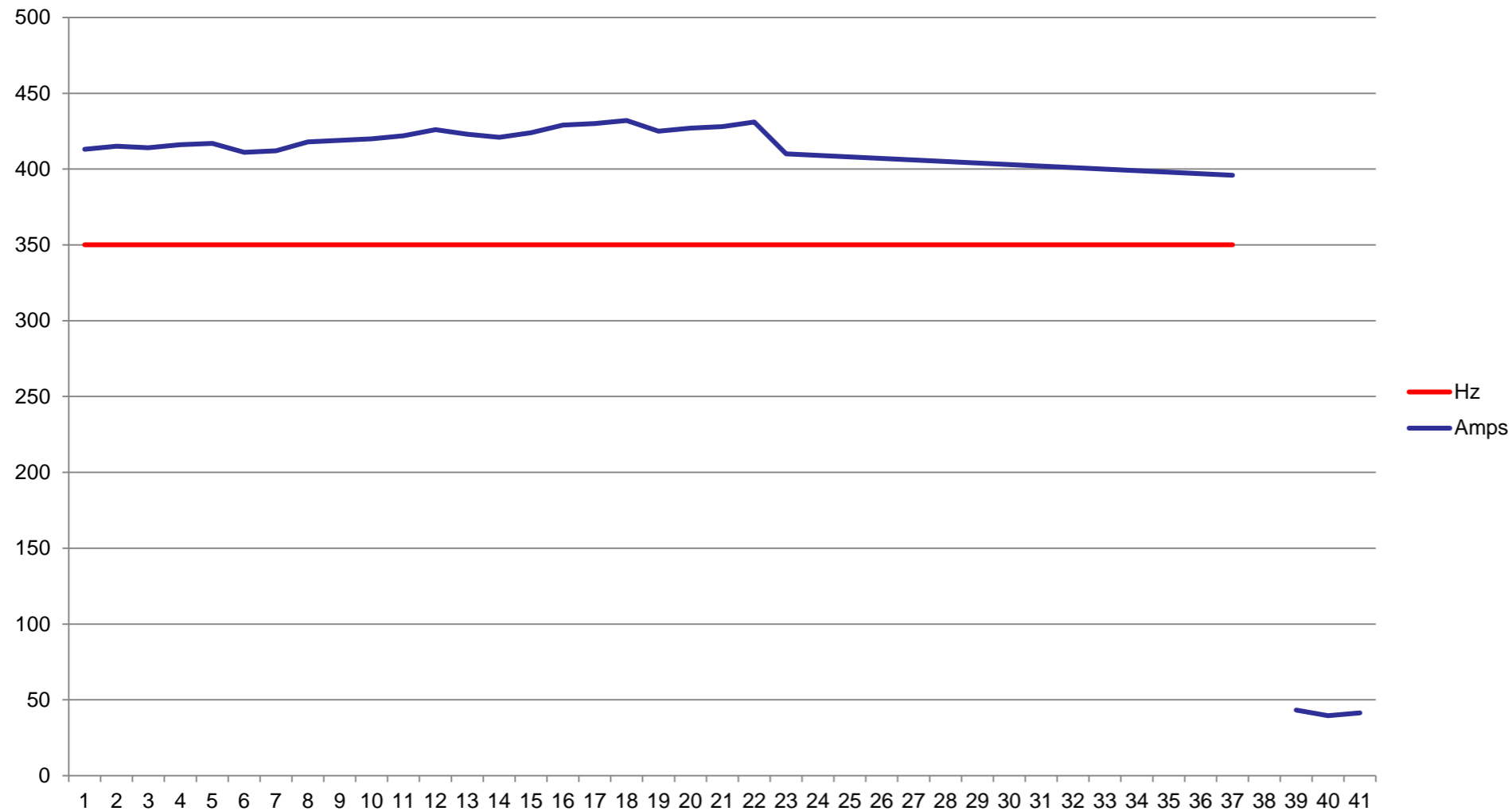

Same pump at the same speed after cleaning, the output current was much more stable, varying only from a minimum of 39.6 Amps, Maximum 43.2 Amps, Average 41.3 Amps. The clean impellor of the pump is considerably more efficient, as displayed by the reduced running current, which represents an energy saving of 12% achieved in this case.

Load Torque Monitoring

- The output current is monitored relative to the output frequency
- The operator can define an under or overload threshold percentage and time
- If the output current falls outside of the defined range, the drive can
 - Trip
 - Carry out the Pump Cleaning Cycle
- An autotune function allows the drive to detect the normal operating conditions
- Under-load (dry pump), Over-load (blocked pump) or combined protection can be selected
- Used to provide Fan Belt Failure or Pump Blockage Detection.



Load Torque Monitoring

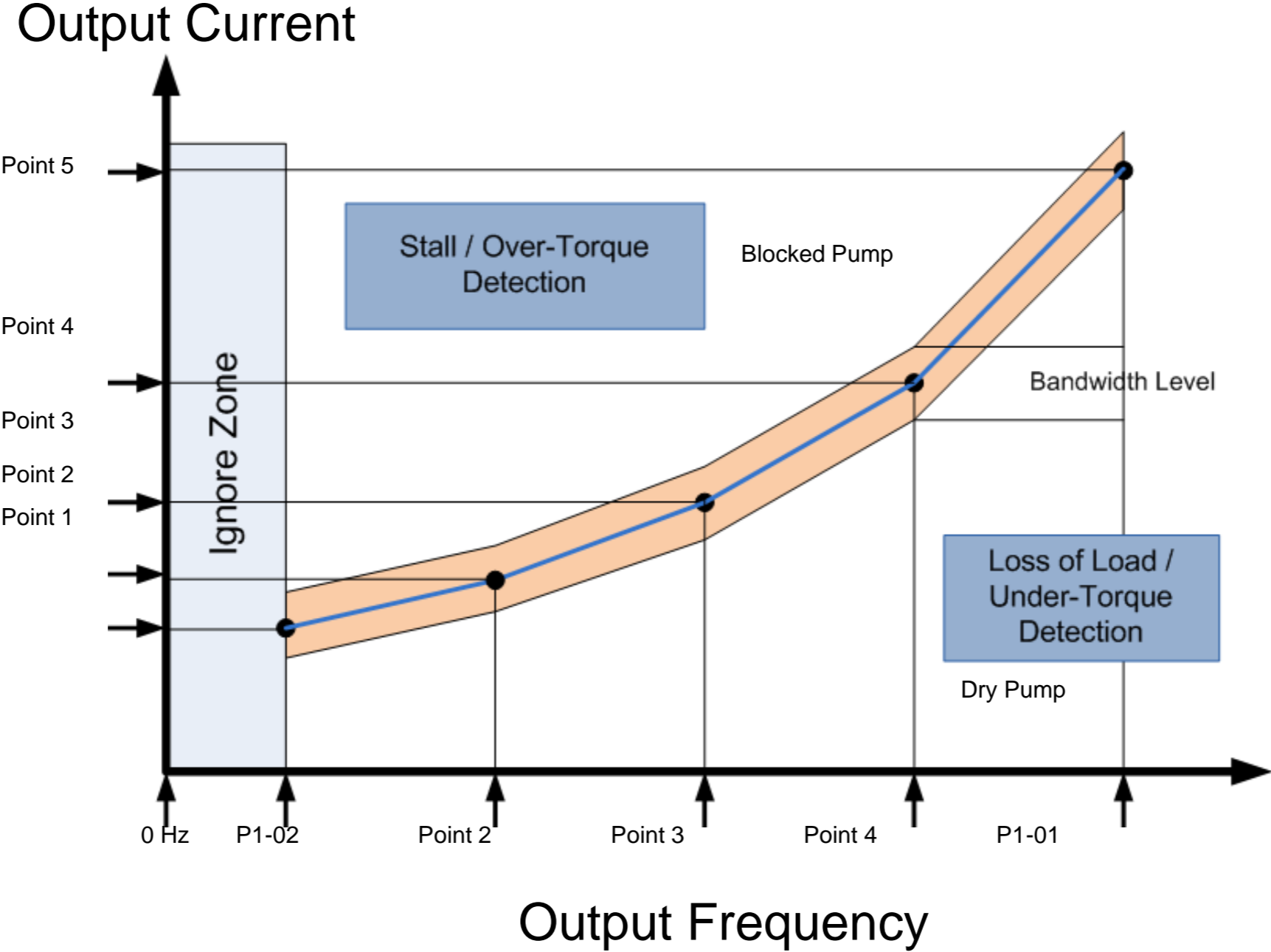

Cascade Control with Fixed Speed Assist

- Used extensively in Pump Booster set applications
- One Drive controls one pump in variable Speed and up to 4 Fixed Speed assist pumps
- Assist Pumps can be DOL, Star Delta, Soft Start etc
- The drive only provides a volt free Start / Stop signal to the assist pumps
- Drive operates in PID mode with a transducer feedback to maintain constant pressure in all operating conditions



Booster Pump Set Control

- Full PID Closed Loop Control
- Variable Speed Duty Pump
- Up to 4 fixed speed assist pumps (Requires Optional Cascade Module)
- DOL pumps brought on and off line as demand requires
- Programmable settle time between DOL pump switching
- Automatic operating time monitoring and balancing for all assist pumps
- Assist pumps can be DOL, Star – Delta or Soft Start

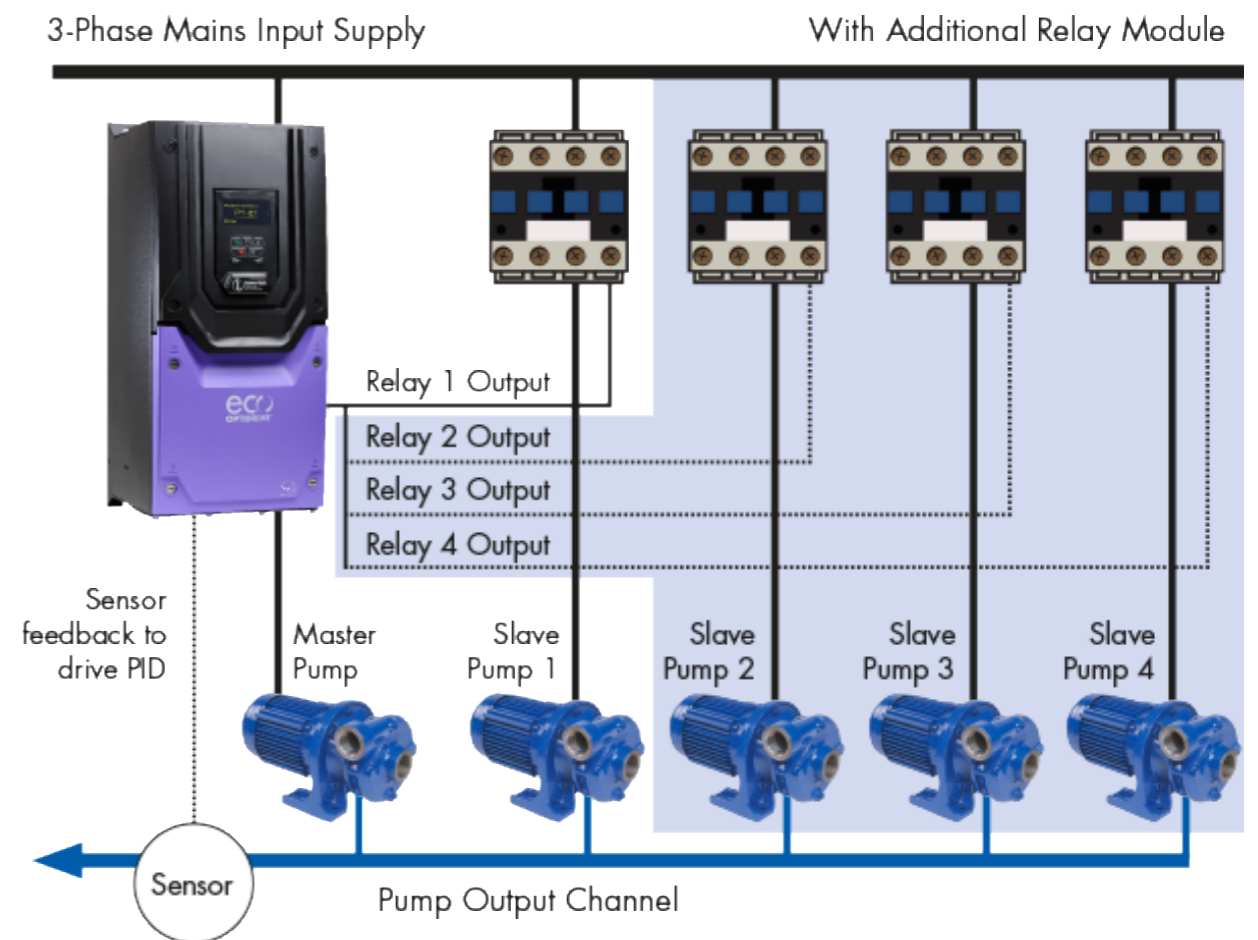

Multi Drive Network Operation

- Optidrive Eco has an unique feature where up to 5 drives may be networked together
- One drive acts as the network Master, and controls the operation of all drives on the network
- The other drives act as slaves under the control of the network

Benefits :-

- Reduced Control Wiring
- Faster Commissioning
- Redundant Operation in all circumstances

Applications :-

- Duty / Standby
- Duty / Assist
- Duty / Assist / Standby
- Jockey Pump mode
- Etc...



Multi Drive Network Operation

- All drives operate as variable speed
- Up to maximum 5 Eco drives can be connected together
- Master drive monitors the running time for all drives and balances operation between them
- Adjustable Switch On / Switch Off duty points to allow system and efficiency optimisation
- Master drive reconfigures the system when drives are unavailable to pump (including the master drive)
- Master drive can be configured to ensure the maximum run time between any two pumps does not exceed a programmed value.

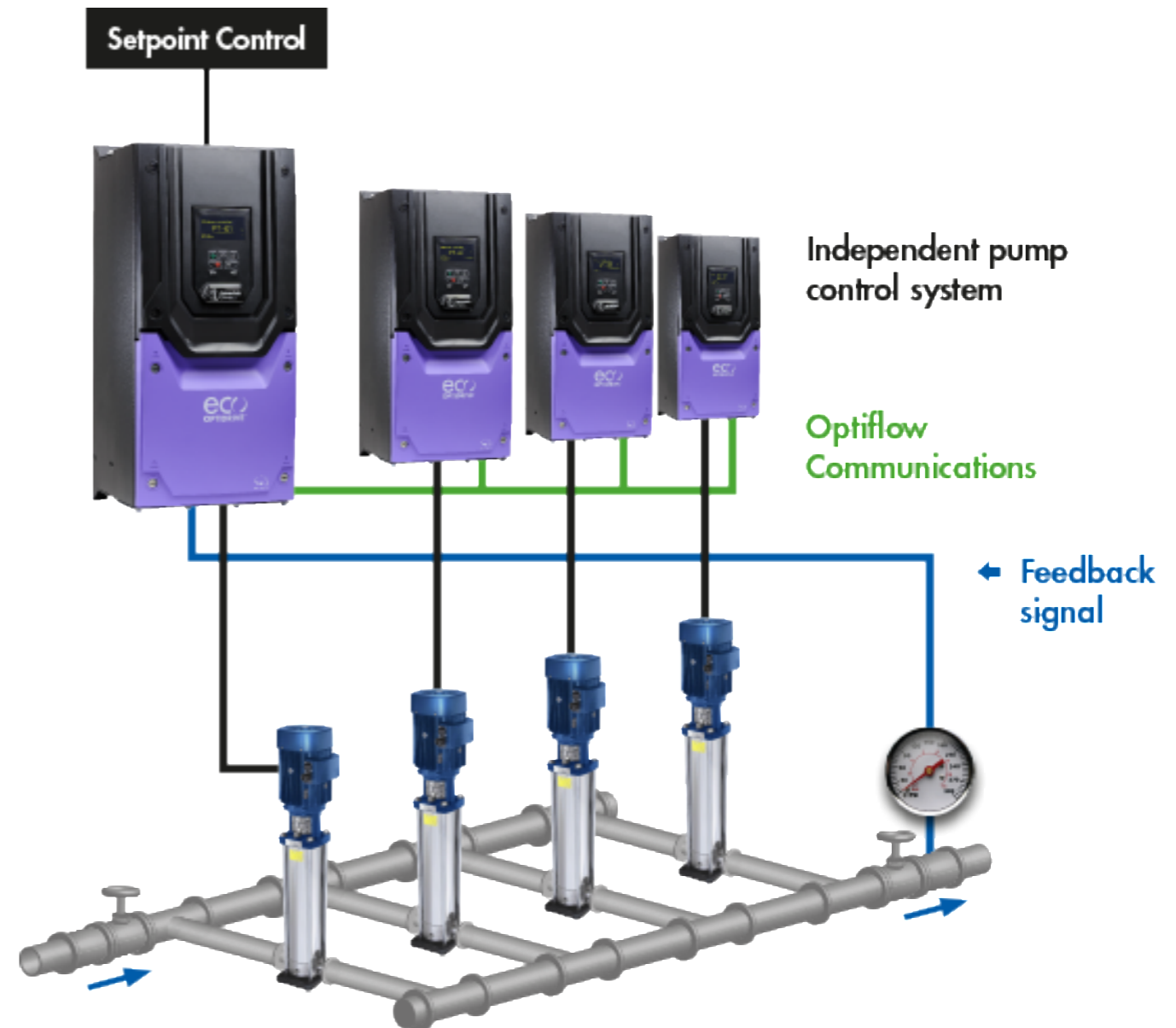

Further Benefits

- System still operates if one or more drives trip
- Drives can be isolated from mains power supply (e.g. for pump maintenance) and the system still operates
- Control power supply shared between all drives using RJ45 connection, hence even the Master can be isolated, and will still control the slave drives.
- Single Bluetooth Optistick can be used to configure the whole network via Optitools Studio

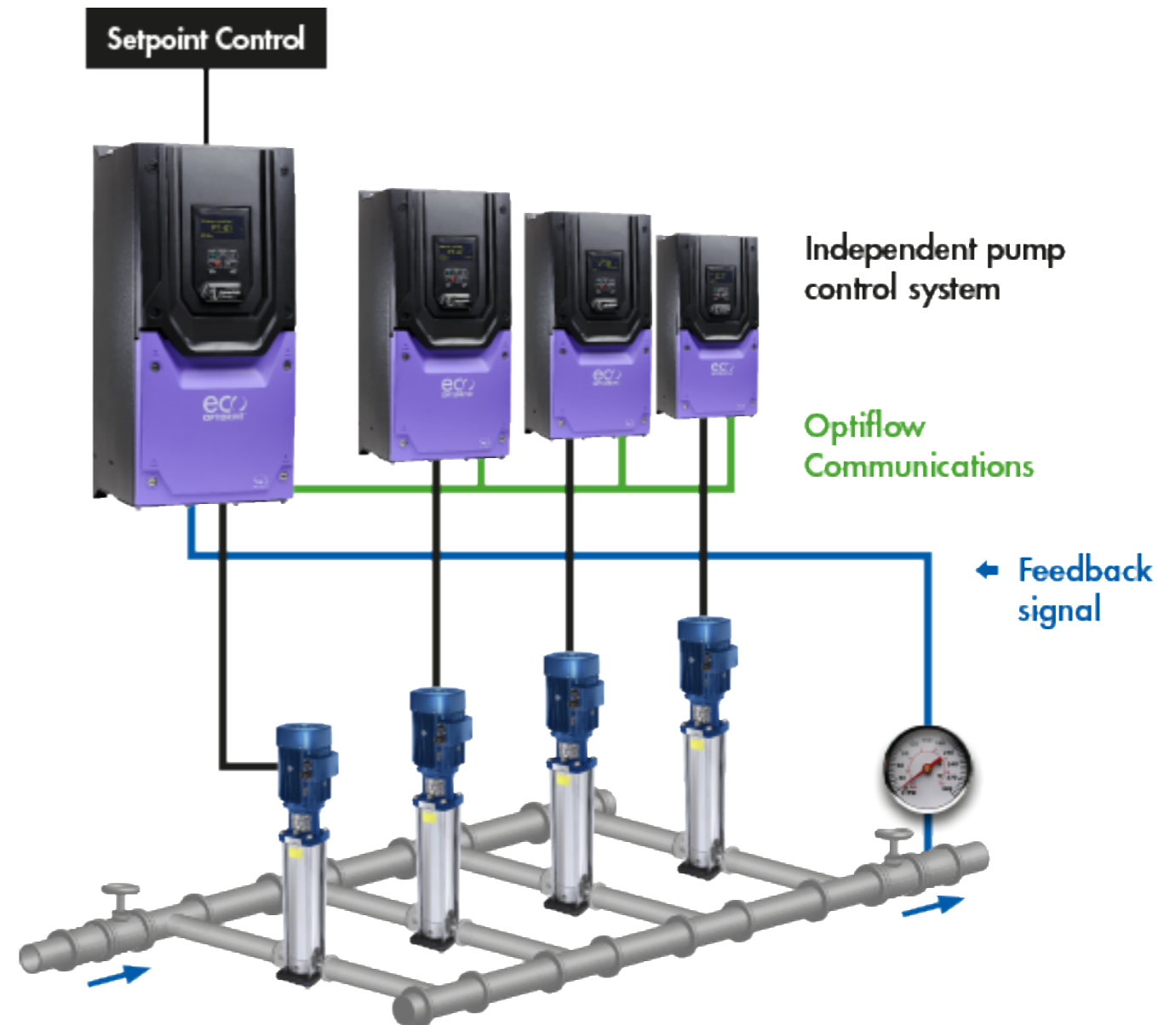

Thank you



eco
OPTIDRIVE™